

# Clarke®



## PRESSURISED SANDBLASTER

MODEL NO: CPSB100B

PART NO: 7640133

## OPERATION & MAINTENANCE INSTRUCTIONS

UK  
CA | CE

ORIGINAL INSTRUCTIONS

DL0822 REV 1

---

## INTRODUCTION

---

Thank you for purchasing this CLARKE Pressurised Sandblaster.

Before attempting to use this product, please read this manual thoroughly and follow the instructions carefully. In doing so you will ensure the safety of yourself and that of others around you, and you can look forward to your purchase giving you long and satisfactory service.

---

## GUARANTEE

---

This product is guaranteed against faulty manufacture for a period of 12 months from the date of purchase. Please keep your receipt which will be required as proof of purchase.

This guarantee is invalid if the product is found to have been abused or tampered with in any way, or not used for the purpose for which it was intended. Faulty goods should be returned to their place of purchase, no product can be returned to us without prior permission.

This guarantee does not effect your statutory rights.

---

## ENVIRONMENTAL PROTECTION

---



Recycle unwanted materials instead of disposing of them as waste. All tools, accessories and packaging should be sorted, taken to a recycling centre and disposed of in a manner which is compatible with the environment.

---

## CARTON CONTENTS

---

The following items should be supplied in the carton. If any parts are missing or damaged, please see your Clarke dealer.

- 1 x Tank Assembly
- 2 x Handlebars
- 2 x Wheels
- 1 x Fixings Kit
- 1 x Media Hose
- 1 x Sand Sieve
- 1 x Protective Mask/Hood
- 4 x Nozzles - nominal diameters: 2.0 mm, 2.5 mm, 3.0 mm, 3.5 mm
- 1 x Front Leg
- 1 x Gun Assembly
- 1 x Axle
- 1 x Funnel
- 1 x Roll Teflon Tape
- 1 x Spare Gun Closing Block

---

# GENERAL SAFETY RULES

---



**WARNING: COMPRESSED AIR CAN BE DANGEROUS. ENSURE THAT YOU ARE THOROUGHLY FAMILIAR WITH ALL PRECAUTIONS RELATING TO THE USE OF COMPRESSORS AND COMPRESSED AIR SUPPLIES.**

---

1. Read this instruction manual before connecting the sandblaster to your compressor.
2. **DO NOT** use any silica based abrasives with this tool. Silica based abrasives have been linked to severe respiratory disease. Always use recommended abrasives. Abrasives used in this sandblaster may be covered by COSHH Regulations.
3. Read this manual carefully, Learn the sandblaster applications and limitations, as well as potential hazards specific to it.
4. **DO NOT** expose to moisture. Don't use this product in damp or wet locations, Keep out of rain.
5. Keep work area clean and well lit. Cluttered or dark work areas invite accidents.
6. Keep children away. All children should be kept away from the work area. Never let a child handle tools without strict adult supervision.
7. **DO NOT** operate this product if under the influence of alcohol or drugs. Read warning labels on prescriptions to determine if your judgment or reflexes are impaired while taking medication. If there is any doubt, do not attempt to operate.
8. **ALWAYS** use safety equipment. Dust mask, non-skid safety shoes, hard hat, or hearing protection should be used in appropriate conditions.
9. Don't overreach, Keep proper footing and balance at all times when operating this product.
10. **ALWAYS** disconnect the sandblaster from the air supply and release pressure from the tank before storing, servicing, or changing accessories.
11. Use clamps or other practical means to secure and support the work piece to a stable platform. **DO NOT** hold the work by hand or against your body.
12. **DO NOT** point the sandblaster at anyone or at any objects other than the intended work object.
13. Check your sandblaster regularly for damage, If any part is damaged it should be carefully inspected to make sure that it can perform its intended function correctly. If in doubt, the part should be repaired. Refer all servicing to a qualified technician. Consult your dealer for advice.
14. **DO NOT** attempt to operate this product near flammable materials or combustibles. Failure to comply may cause serious injury.
15. **ALWAYS** make sure that the trigger is not on before connecting the sandblaster to the air supply.
16. Store idle equipment out of the reach of children and untrained persons. Tools may be dangerous in the hands of untrained users.

17. Drain the water trap periodically during use, **DO NOT** allow moisture to fill more than 1/2 of the water trap bowl. **DO NOT** leave water standing in the water trap when storing the sandblaster.
18. **DO NOT** allow the sandblaster to sit pressurized while unattended or not in use.
19. Periodically check the abrasive medium delivery components. Valves, hoses and nozzles that carry the abrasive medium after it leaves the pressure tank are subjected to the abrasive blasting action so will wear out more quickly than other components.
20. Release the air pressure in the tank before opening. See "Releasing Pressure from the Tank" section, Make sure pressure gauge reads "0" before opening the tank. **DO NOT** attempt any maintenance on the sandblaster until the pressure gauge reads "0" and it has been disconnected from the air supply.
21. Maintain the correct air pressure whenever working. **DO NOT** allow working pressure to exceed 125 psi. If the safety valve does not release excess air pressure, stop all work and release pressure from the tank (see "Releasing Pressure from the Tank" section).
22. **ALWAYS** make sure there is adequate ventilation. **DO NOT** work in confined areas.
23. In the case of injury seek expert medical advice immediately.
24. Use clamps or a vice to hold the work if it is small or light weight rather than using your hands. This frees both hands to operate the nozzle.

---

## ASSEMBLY

---

### FIT THE PRESSURE GAUGE TO THE TANK

1. Screw the pressure gauge onto the sandblaster as shown in Fig 1.

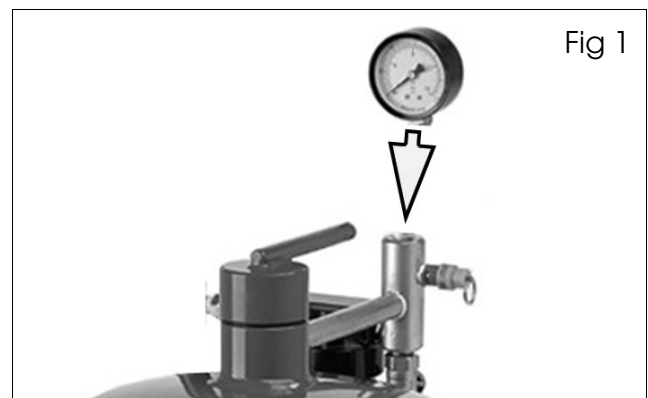

### FIT THE HANDLE BARS TO THE TANK

1. Lay the tank on a flat level surface such as a workbench, with the handlebar mounting brackets facing up, as shown in Fig 2.
2. Align the holes in the left handlebar with the handlebar mounting brackets on the left side of the tank.

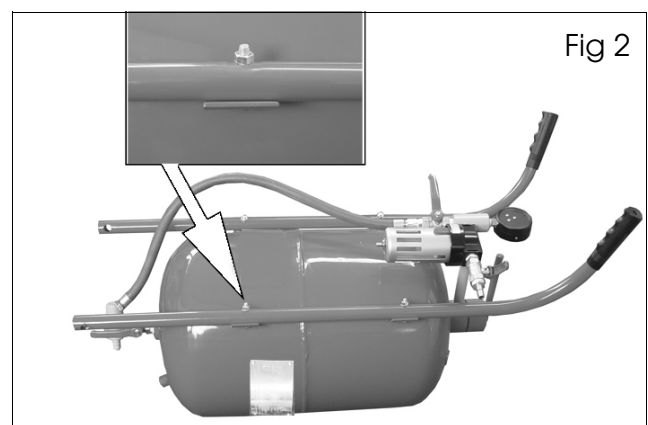

3. Fit a washer onto each of the four handlebar mounting screws. Insert a screw through each of the holes in the handlebar and mounting brackets,
4. Fit a nut onto each of the screws and firmly tighten with a wrench.
5. Repeat steps 2-4 for the right handlebar.

### ASSEMBLE THE AXLE

1. Slide the axle through the holes at the bottom of the handlebars, see Fig 3.
2. Slide a washer onto each end of the axle.

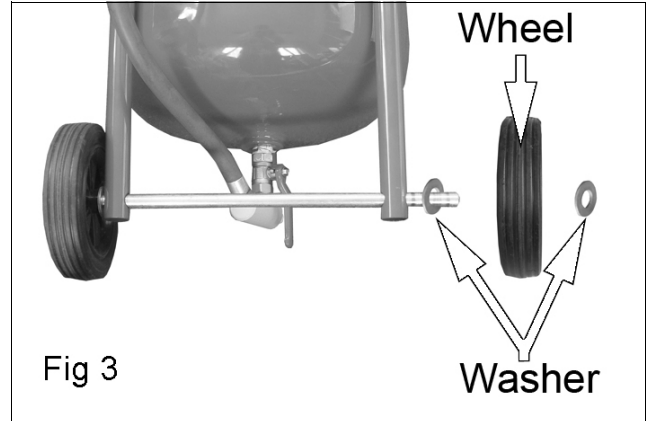

3. Slide a wheel onto each end of the axle followed by another washer.
4. Slide a split pin through the holes in each end of the axle and bend it so that the wheels/washers cannot slide off, see Fig 4.

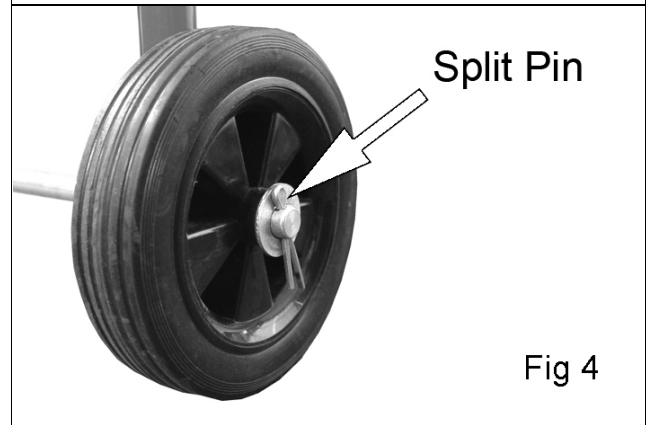

### ATTACH THE FRONT LEG

1. Roll the tank over so that the handlebars are now facing down.
2. Align the holes of the leg with the holes in the leg mounting on the tank, see Fig 5.
3. Insert the split pin through the holes and bend it so the front foot cannot slide off the leg mount.

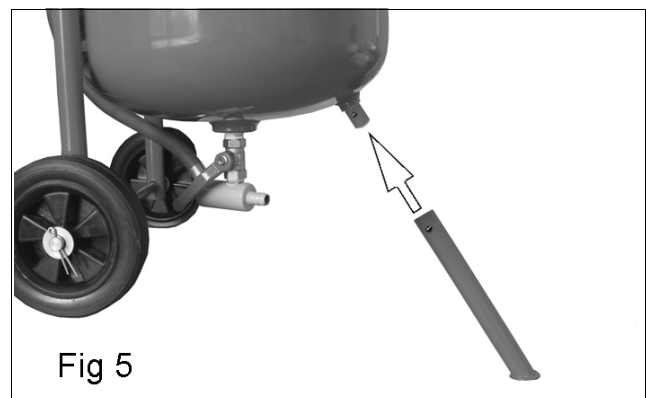

## ATTACH THE MEDIA HOSE

1. Slide the hose onto the outlet at the bottom of the sandblaster as shown in Fig 6.
2. Tighten the clip shown to secure the hose.
3. Connect the sandblasting gun to the other end of the hose using a suitable spanner to ensure an air-tight seal. Ensure the inlet connector is tightly fitted to the gun.
  - A spare gun closing block is supplied for future use.

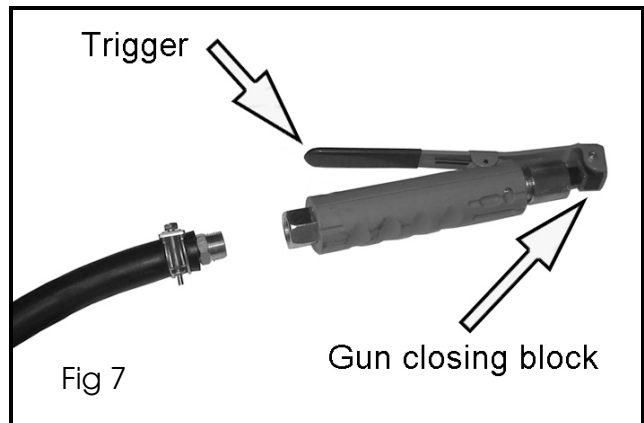
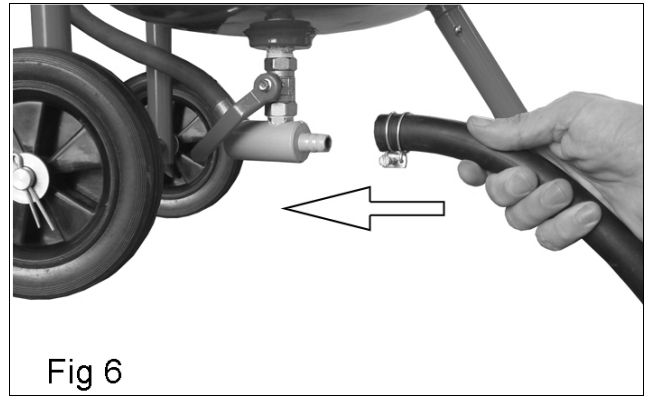

---

## OPERATION

---



**WARNING: ALWAYS WEAR YOUR HOOD, DUST MASK AND HEAVY DUTY CANVAS GLOVES WHEN OPERATING THE SANDBLASTER.**

**WARNING: BEFORE OPERATING YOUR SANDBLASTER, INSPECT EACH CONNECTION, DOUBLE CHECKING TO MAKE SURE THAT ALL ARE TIGHT AND PROPERLY SEALED.**

**WARNING: THIS SANDBLASTER IS NOT INTENDED FOR USE WITH SILICA BASED ABRASIVES. WHICH HAVE BEEN LINKED TO SEVERE RESPIRATORY DISEASE. ALWAYS USE SILICA SUBSTITUTES (SUCH AS CLARKE GLASS BEAD ABRASIVE).**

---

### SAFETY AND HEALTH CONSIDERATIONS

- Before opening the tank make sure it is not pressurized. Ensure the pressure gauge reads "0". If it does not, release pressure from the tank (See page 9).
- Disconnect the compressor before opening the tank. Protect yourself and those around you from "over-spray". Remember that your sandblaster is shooting a powerful spray of abrasive material. **DO NOT** point it at yourself or anyone around you.
- Wear protective clothing including protective hood and heavy gloves when using this sandblaster.

- Wear a dust mask over your mouth when using this sandblaster. You will create a cloud of abrasive material and debris which is dangerous to inhale.
- Protect anything around you that may be damaged from the spray of abrasive particles. Nothing subject to contamination damage or with a fine surface should be near your sandblaster work area.

### ABRASIVE SELECTION AND LOADING

The type of abrasive you choose will greatly influence the amount of time needed to clean a given surface area. See page 12 for suitable abrasives.

- To prevent clogging, ensure that the abrasive you use is dry.
- While you may re-use abrasive but remember that abrasive grit/material does wear out. With use, abrasive becomes smoother and rounder, thus reducing its effectiveness.

**NOTE:** Re-using abrasive may also cause clogging due to fine debris contained in the medium from prior use.

4. Close the air supply valve by turning it to the closed position, see Fig 8.
5. Squeeze the trigger to release any pressure from the tank.
  - Make sure the pressure gauge reads "0".
6. Remove the filler cap.

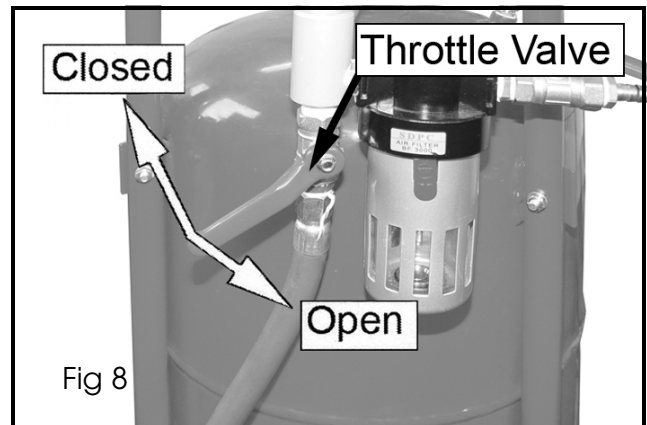

7. Using the sieve and funnel supplied, pour the abrasive material into the tank, see Fig 9.
  - Do not fill the tank more than  $\frac{3}{4}$  full.
  - If humidity in your region is 90% or more, only fill the tank  $\frac{1}{2}$  full and check the water trap more frequently.
8. Replace the filler cap ensuring the O-ring is in place.



**NOTE:** Position your air compressor in another room to prevent damage from the intake of abrasive dust laden air.

### ABRASIVE FLOW ADJUSTMENT

- Choose a larger nozzle for a broader spray pattern. Choose a smaller nozzle for more focused spray.
- Adjust air pressure with the throttle valve. Adjust abrasive flow with the abrasive control valve.
- Watch for abrasive clogging. Release pressure from the tank if necessary and replace the abrasive with drier or cleaner abrasive.

## TO START BLASTING

**NOTE:** Start with all valves in the closed position. Following the instructions below will help prevent clogging in the delivery hose, outlet manifold and the gun.

1. Connect the compressor to the inlet connector.
2. Start the compressor and open the air supply valve, see Fig 10.
  - The tank will start to pressurise.
3. Test the safety valve by pulling on the valve as shown in Fig 11.
  - Air will hiss out when the valve is pulled.
4. Open the throttle valve, Fig 12.
5. Check for leaks at the filler cap and along all hoses and fittings as the system pressurises. If leaks are observed, release the pressure from the tank and repair any leaks immediately.
6. Squeeze and hold the trigger until air is flowing through it.
7. With the trigger open, slowly open the abrasive control valve as shown in Fig 13 until abrasive begins to flow out of the nozzle.
8. Adjust the abrasive medium control valve until the desired amount of abrasive material is flowing through the gun.
9. Begin blasting.

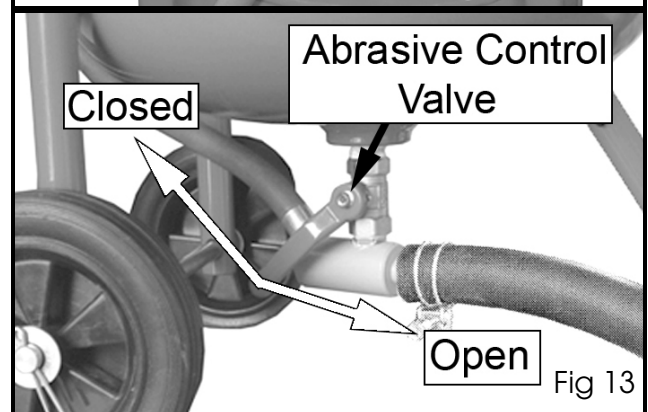
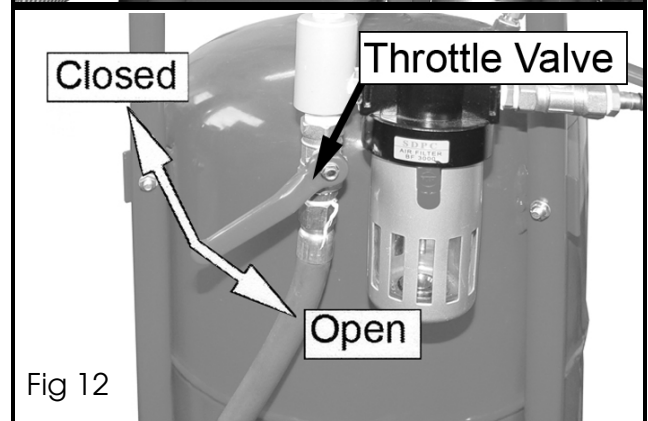
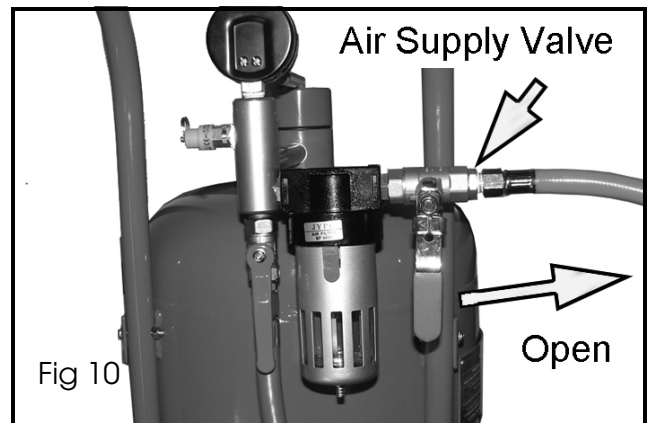



## TO STOP BLASTING

1. While continuing to squeeze the trigger, turn the abrasive control valve to the closed position, see Fig 14.
2. When you notice only air (no abrasive material) is coming out of the gun, you can stop the air flow by releasing the trigger. By doing this you are ensuring a clean manifold, hose and gun.
3. ALWAYS clean the gun thoroughly after use.

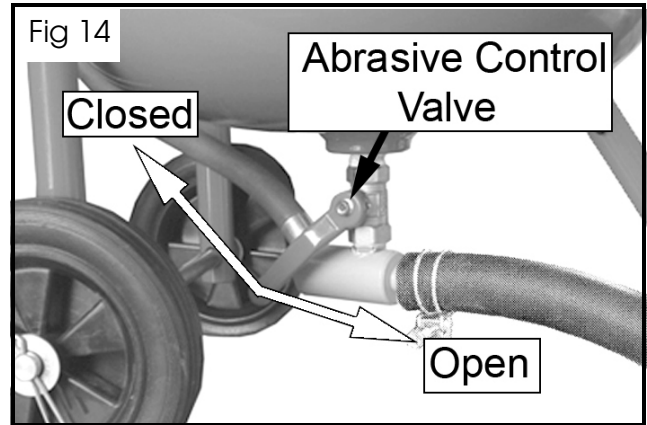

## RELEASING PRESSURE FROM THE TANK

1. When finished blasting, close the abrasive control valve, see Fig 15.
2. Squeeze the trigger to expel any remaining abrasive material from the abrasive media hose and gun.
3. When you notice only air (no abrasive material) is coming out of the nozzle, close the Air Supply Valve, see Fig 16.

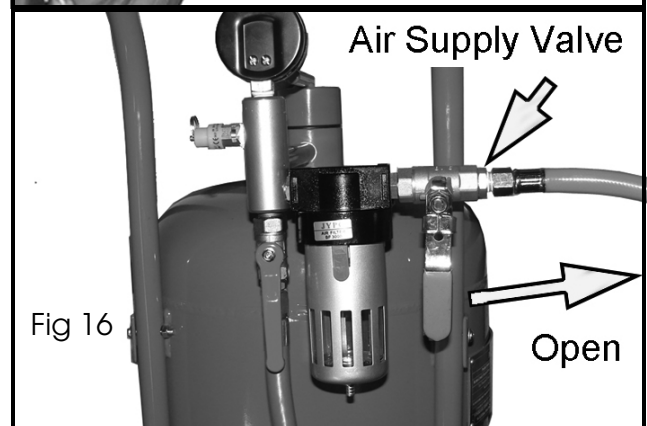
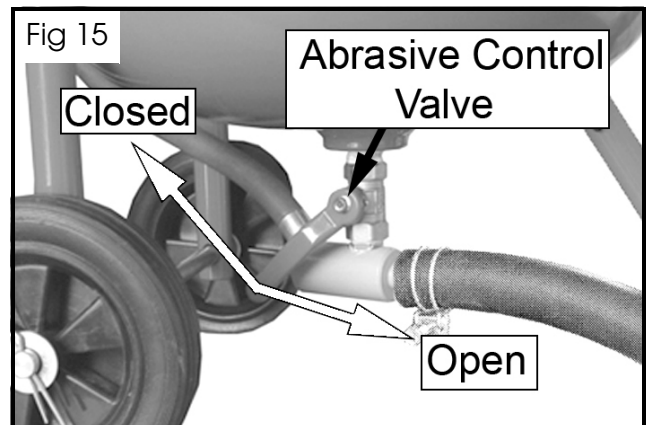

4. Ensure the throttle valve is open, see Fig 17.
5. Point the gun in a safe direction.
6. Squeeze the trigger until air stops flowing and the pressure gauge reads "0".
7. Disconnect air supply hose from the supply valve.

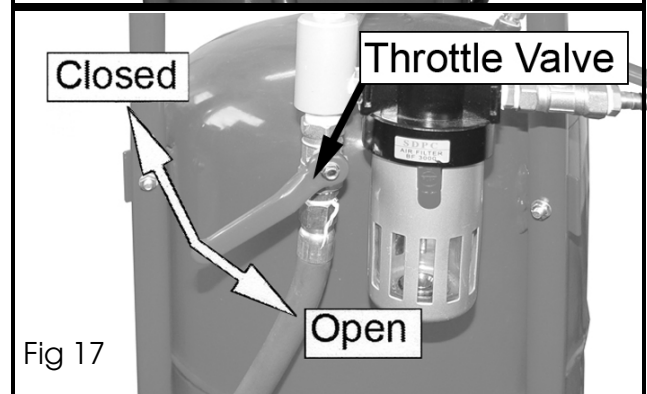

---

# MAINTENANCE

---



**WARNING: DISCONNECT THE SANDBLASTER FROM THE AIR SUPPLY BEFORE CHANGING ACCESSORIES, ATTEMPTING TO MOVE THE SANDBLASTER OR PERFORMING ANY MAINTENANCE.**

---

1. Keep your sandblaster clean and protect it from damage.
2. When initially pressurising, check for leaks at the top of the tank and at all hoses and fittings.
3. Leaking joints maybe repaired by replacing worn or damaged parts or using teflon tape.
4. Check for worn abrasive hose and fittings.
5. Watch for leaks, blistering, bulging or thinning of the hose.
6. Replace any parts which appear worn.

## AIR FILTER

### DRAINING

Condensation will collect in the air filter which must be drained manually.

1. Drain the air filter by pulling down on the drain plug until all the water comes out, see Fig 18.

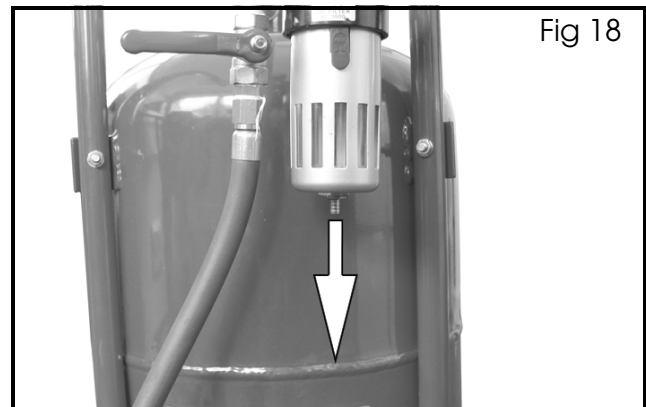

### CLEANING/REPLACING

1. Press the release catch and unscrew the condensation chamber, see Fig 19.

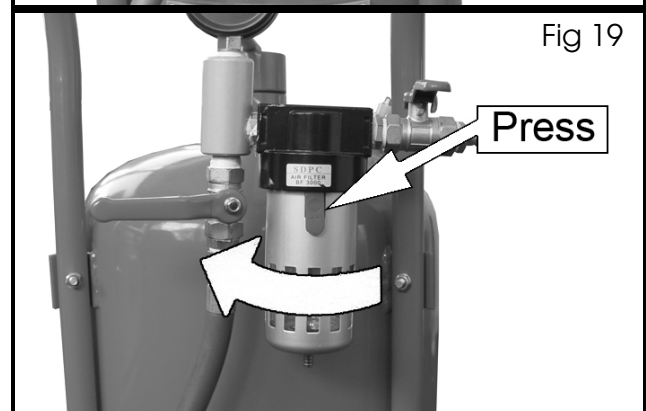

2. Unscrew the filter as shown in Fig 20 and wipe clean.

**NOTE:** Do not use harsh or abrasive chemicals when cleaning the condensation chamber.

3. Refit the condensation chamber.

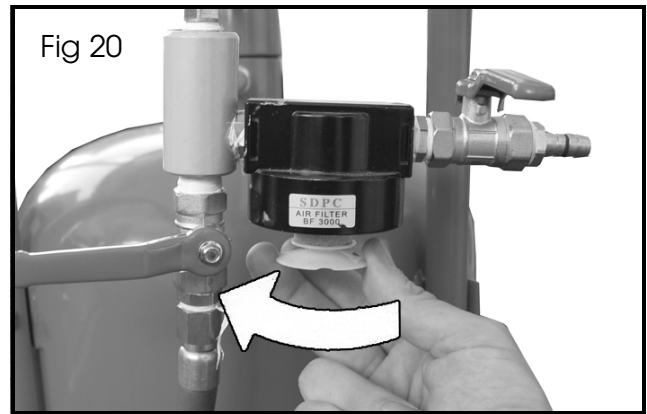

### REPLACING THE NOZZLE

**NOTE:** ONLY use identical replacement parts when servicing.

After 10-12 hours of blasting time the nozzle should be checked for wear. The nozzle will wear out over time and should be replaced when the hole is no longer round or the abrasive media does not flow smoothly through. To replace the nozzle:

- Refer to page 14 for the following replacement parts.

1. Disconnect the sandblasting gun from the air hose.
2. Unscrew the nozzle adapter (38), located at the front of the sandblasting gun.
3. Remove the old nozzle (37).
4. Insert the new nozzle.
  - A pack of 4 replacement nozzles are available from your Clarke dealer: Part number 7640132.
5. Replace the nozzle adapter (38) and firmly screw it onto the gun.
  - Keep your sandblaster clean and protect it from damage.
  - Check for a worn abrasive material hose and fittings. Watch for leaks, blistering, bulging or thinning of the hose.
  - Replace any parts which appear worn.

### SUITABLE ABRASIVES AVAILABLE FROM YOUR CLARKE STOCKIST

Aluminium Oxide Powder	60	60-80	60-80	80	80-120	120
	22kg	20kg	7.5kg	22kg	7.5kg	22kg
	3052070	3052110	3052100	3052075	3052105	3052080
Glass Bead Abrasive	3052095	20kg				
Soda Blast Abrasive	3052805	7.5kg		3052800	22kg	
Garnett Abrasive	3052090	22kg				

---

## SPECIFICATIONS

---

Sand Grade Type	Above 60-120 grit
Abrasive Material	Aluminium Oxide, Sand, Garnet, Glass Beads
Tank Capacity (working)	32 Litres (7.04 Gallons)
Operating Pressure	65 - 125 PSI (4.4 - 8.6 Bar)
Flow Rate Required	169-707 l/min (6 - 25 CFM) depending on nozzle & hose size
Min Compressor Size	2-10 HP (dependant on settings)
Nozzle Sizes	2, 2.5, 3, 3.5 mm
Dimensions (L x W x H)	500 x 855 x 345 mm
Weight (empty)	21 kg

# EXPLODED DIAGRAM

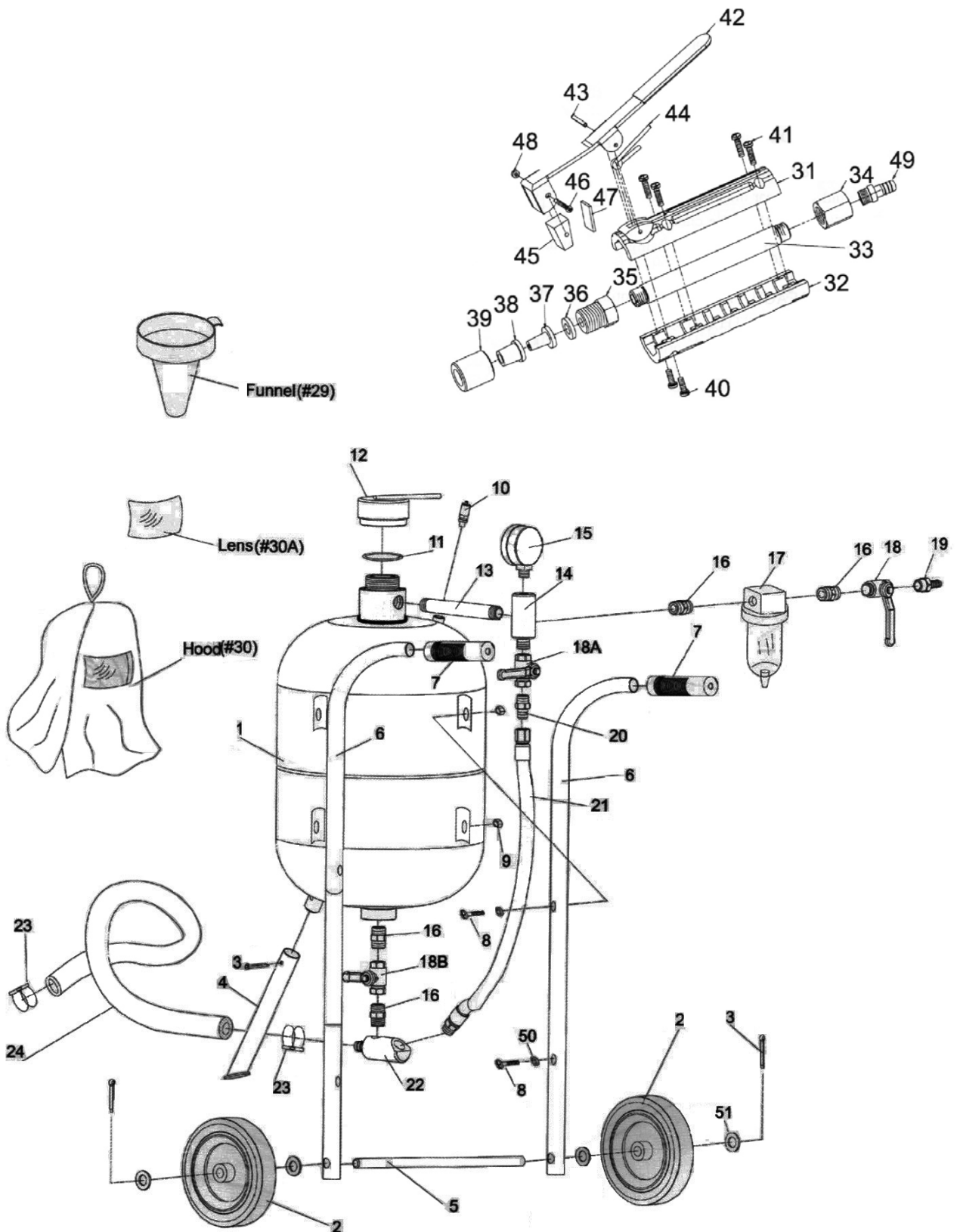

# PARTS LIST

NO	DESCRIPTION	NO	DESCRIPTION
1	Tank	24	Abrasive Media Hose
2	Wheel	29	Funnel
3	Cotter Pin	30	Hood
4	Front Leg	30A	Lens (for Hood)
5	Axle	31	Upper Gun Body
6	Handle Bar	32	Lower Gun Body
7	Handle Grip	33	Metal Pipe
8	Pan Head Screw	34	Inlet Connector
9	Hex Nut	35	Adapter
10	Safety Valve	36	O-Ring
11	O-Ring	37	Ceramic Nozzle
12	Tank Filler Cap	38	Rubber Adapter
13	Connecting Pipe	39	Nozzle Cap Nut
14	Intake Manifold	40	Screw ST 4.2 x 16
15	Pressure Gauge	41	Screw ST 4.2 x 12
16	3/8" Connector	42	Trigger
17	Water Trap Filter	43	Spring Pin
18	3/8" Brass Air Supply Valve	44	Spring
18A	3/8" Brass Throttle Valve	45	Rubber Pad
18B	3/8" Steel Abrasive Control Valve	46	Screw M3 x 25
19	Inlet Connector	47	Hard Alloy Pad
20	Connector	48	Nut M3
21	Air Hose	49	Hose Adapter
22	Abrasive Outlet Manifold	50	Washer
23	Hose Clamps	51	Washer

# DECLARATION OF CONFORMITY



Hermell Street, Epping, Essex CM16 4LG

## DECLARATION OF CONFORMITY

This is an important document and should be retained.

We hereby declare that this product(s) complies with the following statutory requirement(s):

*Pressure Equipment (Safety) Regulations 2016*  
*Supply of Machinery (Safety) Regulations 2008*

The following standards have been applied to the product(s):

EN 1248:2001 + A1:2009, EN 12100:2010

The technical documentation required to demonstrate that the product(s) meet(s) the requirement(s) of the aforementioned legislation has been compiled and is available for inspection by the relevant enforcement authorities.

The UKCA mark was first applied in: 2022

Product Description: 32L Pressurised Sandblaster  
Model number(s): CPSB100B  
Serial / batch Number: N/A  
Date of issue: 22/07/2022

Signed:

J.A. Clarke  
Director



Fitzwilliam Hall, Fitzwilliam Place, Dublin 2

## DECLARATION OF CONFORMITY

This is an important document and should be retained.

We hereby declare that this product(s) complies with the following directive(s):

*2014/68/EU Pressure Equipment Directive*  
*2006/42/EC Machinery Directive*

The following standards have been applied to the product(s):

EN 1248:2001 + A1:2009, EN 12100:2010

The technical documentation required to demonstrate that the product(s) meet(s) the requirement(s) of the aforementioned directive(s) has been compiled and is available for inspection by the relevant enforcement authorities.

The CE mark was first applied in: 2017

Product Description: 32L Pressurised Sandblaster  
Model number(s): CPSB100B  
Serial / batch Number: N/A  
Date of issue: 22/07/2022

Signed:

J.A. Clarke  
Director

# A SELECTION FROM THE VAST RANGE OF

# Clarke®

## QUALITY PRODUCTS



### AIR COMPRESSORS

From DIY to industrial, Plus air tools, spray guns and accessories.

### GENERATORS

Prime duty or emergency standby for business, home and leisure.

### POWER WASHERS

Hot and cold, electric and engine driven - we have what you need

### WELDERS

Mig, Arc, Tig and Spot. From DIY to auto/industrial.

### METALWORKING

Drills, grinders and saws for DIY and professional use.

### WOODWORKING

Saws, sanders, lathes, mortisers and dust extraction.

### HYDRAULICS

Cranes, body repair kits, transmission jacks for all types of workshop use.

### WATER PUMPS

Submersible, electric and engine driven for DIY, agriculture and industry.

### POWERTOOLS

Angle grinders, cordless drill sets, saws and sanders.

### STARTERS/CHARGERS

All sizes for car and commercial use.

## PARTS & SERVICE: 0208 988 7400

**Parts Enquiries**  
[Parts@clarkeinternational.com](mailto:Parts@clarkeinternational.com)

**Servicing & Technical Enquiries**  
[Service@clarkeinternational.com](mailto:Service@clarkeinternational.com)

SALES: UK 01992 565333 or Export 00 44 (0)1992 565335

**Clarke** INTERNATIONAL Hemnall Street, Epping, Essex CM16 4LG  
[www.clarkeinternational.com](http://www.clarkeinternational.com)